

BEFORE OPERATING:

The Aurand KP Pneumatic Tool has been thoroughly tested and shipped complete, but **DO NOT** attempt to operate without reading the following instructions.

1. The air line must have automatic filtering and lubrication. The compressed air to the motor must be free of moisture and dirt or damage will occur. The equipment must be capable of handling at least 43 cu. ft. of air per minute at 90 lbs. air pressure.
2. Connect to air line, using a minimum 3/8" inside diameter hose.

OPERATING INSTRUCTIONS:

1. Wear safety glasses and hearing protection.
2. Grasp both handles and raise front of tool from surface.
3. Squeeze trigger and allow cutters to come up to speed before applying to surface.
4. Using both hands, guide tool in a forward and backward motion to assure complete coverage. Let weight of tool do the work. Never apply pressure as this will slow down motor speed and cause damage to motor, gears, and cutter bundles.

DEPTH ADJUSTMENT:

When adjustment is required to compensate for cutter wear:

1. Loosen SCREW (Ref 7M)
2. Move DEPTH SHOE (Ref 611) up or down as required. (Cutters should have play in them when touching work surface)
3. Tighten SCREW (Ref 7m)

CUTTER BUNDLE REPLACEMENT:

1. Install COTTER PIN & WASHER (Ref 76M) on both ends of SPINDLE (Ref 643 or 643E). Cutter tips must point in direction of rotation.
2. Slide CUTTER BUNDLE (Ref 674) and CUTTER BUNDLE FELT (Ref 645) from SPINDLE.
3. Slide new CUTTER BUNDLE FELT & CUTTER BUNDLES on SPINDLE, with large round hole facing side plate. CUTTER TIPS must point in direction of rotation.
4. Install COTTER PINS & WASHER on both ends of SPINDLE.

LUBRICATION:

Check grease (676) in Gear Housing after every 9 hours of operation .
Remove KNOB (Ref 608).
With tool sitting level add 676 GREASE through hole.
Then replace SCREW & PLUG.



Aurand Manufacturing & Equipment Company

1210 Ellis St
Cincinnati OH 45223-1843

800-860-2872 or 513-541-7200

Fax 513-541-3065

www.aurand.net

We gladly accept:



AURAND



KP5
KP5E

Parts List & Operating Instructions

Aurand has manufactured exclusively in the USA since 1937.

AURAND

Motor Sub-Assembly Parts List

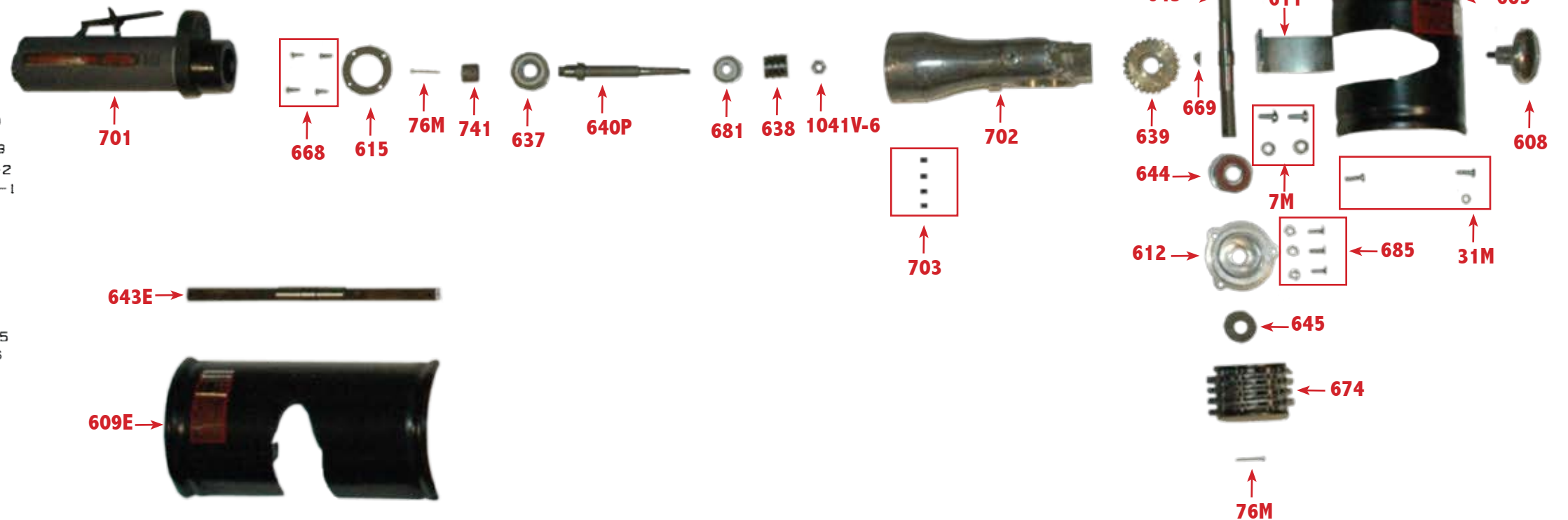
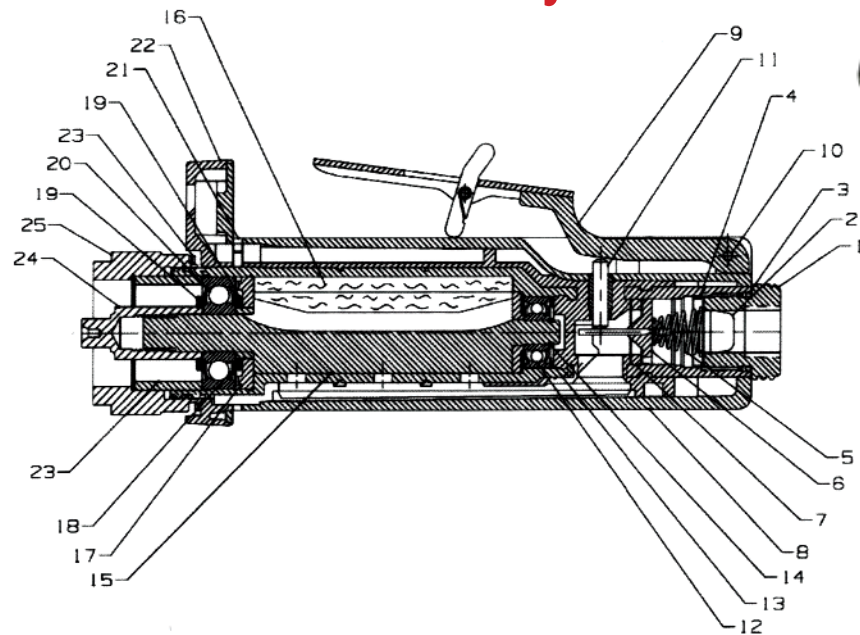

Motor Sub-Assembly Parts List

PART NUMBERS

Item	Description	Part Number	Item	Description	Part Number
1	Inlet Assembly	801	13	Spacer (qty 2)	813
2	Inlet Screen	802	14	Retainer Ring	814
3	Inlet Seal	803	15	Rotor	815
4	Seat	804	16	Vane Packet (4 per packet)	816
5	Spring	805	17	Front Ned Plate	817
6	Throttle Valve	806	18	Spacer	818
7	Throttle Valve Seat	807	19	Seal Cup Assembly	819
8	Motor Housing	808	20	Bearing	820
9	Throttle Lever	809	21	Flow ring	821
10	Throttle Lever Pin	810	22	High Profile Flange	822
11	Plunger	811	23	Clamp Sleeve	823
12	Rear Rotor Bearing	812	24	Driver	824
			25	Nut	825

Numbers in **Red** = stock one (pair or set) for every 4 motors

608	Handle	643	Spindle 5"	702	Front Housing
609	Guard	643E	Spindle 8" (KP5E Model)	703	Set Screw (4)
609E	Guard (KP5E) Model	644	Spindle Bearing (2)	741	Coupling
611	Depth Shoe	645	Cutter Bundle felt (2)	7M	Depth Shoe Screw & Washer (2)
612	Side Plate (2)	647	Spring Washer	31M	Screw & Washer (9)
614	Armature Nut	668	Ret. PL. Screw (6)	76M	Cotter Pin (3)
615	BRG Retainer Plate	669	Woodruff Key		
1041V-6	Worm Nut (RH)	674	Cutter Bundle Set		
637	Worm Shaft Bearing	674E	Cutter Bundle Set (KP5E Not Shown)		
638	Worm	681	Worm Shaft Bearing (2)		
639	Worm Wheel	685	Side PL. Screw & Washer (6)		
640	Worm Shaft	701	Motor Assembly (see inset)		